



FRS 660-25-DPU-MTU-UL

Fuel Recirculating System Specification Sheet

Designed for Dual Pump / Multi-Tank System / 25 GPM

Complete System is NEMA 4 UL 508A Listed

PRODUCT DESCRIPTION:

The FRS 660-25-DPU-MTU-UL (*Duplex Multi-Tank Pumping Unit*) Fuel Recirculating System is **UL 508A Listed** and **Green Clean Certified**. It is designed to automatically circulate and clean fuel utilizing two (2) alternating 25 GPM pumps & motors on a preprogrammed schedule, giving the customer back-up protection. 25 GPM flow rate is provided through the FP 1000 fuel purifier in up to four (4) multiple storage tanks on a preprogrammed schedule.

The FRS 660 25-DPU-MTU UL utilizes **RCI Technologies patented** fuel purification technology, which contains no filters or moving parts. It is used as primary fuel purification and removes 100% of all free water, including emulsified water and up to 98% of the normal solid or particulate contaminants found in fuel, including sludge and algae to approximately 10 microns.

The control system is housed in a **NEMA 4**, key lockable enclosure. The system consists of an RCI Universal Fuel Purifier, (2) continuous duty motors and fuel pumps. The system is PLC controlled, with an Operator Interface Touch Panel that allows for system programming and alarm monitoring. Automatic controls are governed by a programmable 7 day, 24-hour real time clock with user definable start and run times. Four (4) relay alarm outputs include: pump failure, purifier high water level, system high pressure and fuel catch basin leak. Standard internal relays allow alarm status to be remotely monitored in addition to control of the automatic valve.

All electrical components and connections are housed within **NEMA4X** panels. FRS Systems are designed for use with all Class II or III combustible fuels having a flash point of 100° F or higher. Multiple tank operations are available



All RCI Systems are cycle and leak tested for a minimum of 2 hours prior to shipment.

STANDARD FEATURES:

System:

- Listing:
- Approx. shipping weight:
- Power Requirements:

UL 508A
 425 lbs
 Standard: 115 or 230 VAC,
 60Hz, 1Ph *(Please Specify)*

Cabinet:

- Dimensions: 48" W x 42" H x 12" D
- Rating: **NEMA 4**
- Construction: Dual Door, Heavy Duty Powder Coated Steel *(white)*
- Mounting: Suitable for floor or wall mounting *(Wall and Floor Mounting Tabs Included)*
- Security: Individually Keyed Lock
- Fuel Leak Basin w/ Drain: Integral
- Leak Float Switch: 1/8" Liquid Detection
- Pressure Switch: Factory set at 75 psi
- Plumbing and Wiring: Factory assembled and tested

Controls:

- System Controller: **UL 508A** Standard PLC
- Operator Interface: 6" Monochrome Touch Screen Panel
- System Data Display: Touch Screen Interface

Location:

- PLC Controller: In **NEMA 4X** Poly Pro Enclosure
- H/O/A Keyed Selector & Summary Light Combination: Exterior of Front Door
- Test Reset Alarm Button: Exterior of Front Door
- Audible Horn: Exterior of Front Door

Automatic Valves:

- 1" Automatic Ball Valve: 4 for two tanks
6 for three tanks
8 for four tanks

*Motorized ball valves factory preset "Normally Open".
 (If valves are required to be normally closed, please note on purchase order.)*

Fuel Purifier:

- Model Number: FP 1000 Fuel Purifier
- Normal Flow: 40 GPM
- Water Removal: 100%
- Decontamination Unit: BIO-MAG 1"
- Water Drain Valve: 1/2" Brass
- Particulate Removal:
 - Primary: 98% to approx. *(10 micron)*
 - Secondary: Provided by Engine Mfg *(5 micron)*
 - Final Removal: Provided by Engine Mfg *(2 micron)*

Pump:

- Type: (2) Positive Displacement Pumps
- Product to pump: Diesel Fuel
- Pump Rate: 25 GPM
- Pump Housing: Aluminum
- Pump Gears: Steel

Pump Motor:

- Horse Power: (2) 2 H.P.
- Enclosure: TEFC
- Frame: 56C
- Duty: Continuous
- Type: Capacitor Start

Plumbing:

- 2 pcs. Brass 1" Manual Ball Valves *(Fuel Line Input/Output)*
- 1 pc. 1" Y Strainer
- 1 pc. Brass 1" Check Valves
- 3 pcs. Brass 1" Unions

NOTE: For options/upgrades, see Options List. Specifications subject to change without notice.

115 VAC Actuator & Ball Valve

Specification Sheet

PRODUCT NUMBER:

1001

PRODUCT DESCRIPTION:

The 115V Actuator is used on brass motorized ball valves rated at 600 WOG (1/2" for the 5GPM and 11GPM systems, 1" on the 25GPM systems). It is constructed with a NEMA 4 protective cover.

PRODUCT FEATURES:

Product Number	1001
Product Name	115VAC ACTUATOR AND BALL VALVE
Output Torque	100 inch pounds
Cycle Time	2.5 sec/90°
Duty Cycle	75%
Standard Motor	115VAC/60Hz/1ph
Standard Enclosure	NEMA 4
Enclosure Material	Aluminum
Enclosure Coating	Thermal bonding polyester powder
Temperature Rating**	-40°F to +150°F
Thermal Overload Protection	Standard
Manual Override	Standard (omit on NEMA 7)
Lock Rotor Current	0.55 amps
Switches	15A, 1/2 HP 125 250VAC/0.5A/125VDC
Weight	5 pounds

** heater required below 0°F

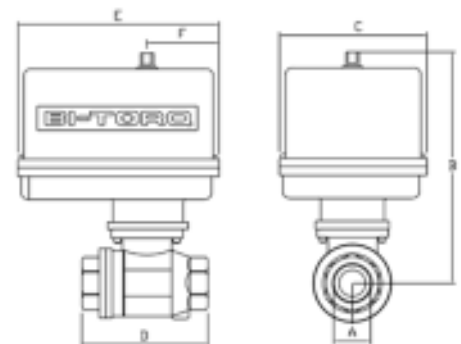

Section	Ball Valve Size		
	1/2"	1"	1 1/2"
A	1.25	1.50	1.88
B	6.13	6.57	8.29
C	4.00	4.00	4.22
D	2.64	3.35	4.13
E	5.63	5.63	5.63
F	2.31	2.31	2.43
ACT.	100E	100E	200E
WT.	5.82	6.35	10.17

IP-Series 2-Piece Brass Ball Valves

PART #	NAME	MATERIAL	OPTIONAL MATERIAL	QTY
1	BODY	BRASS UNI 5705-65	N/A	1
2	ENDS	BRASS UNI 5705-65	N/A	2
3	BALL	BRASS UNI 5705-65 CHROME PLATED	316SS	1
4	SEAT	TFE	N/A	2
5	BODY SEAL	VITON	N/A	2
6	STEM SEAL	TFE	N/A	1
7	BODY O-RING	VITON	N/A	2
8	STEM O-RING	VITON	N/A	1
9	STEM NUT	BRASS UNI 5705-65	316SS	1
10	STEM	BRASS UNI 5705-65	316SS	1

VALVE FEATURES

- Full port brass valve 1/4" through 4"
- Optional stainless Steel ball & stem 1/4" through 2"
- TFE® seats and seals
- Viton® body o-rings
- ISO mounting pad
- Blowout proof stem
- CE rated

PRESSURE RATING

600 WOG

TEMPERATURE RATING

+297°F Maximum

ACTUATOR FEATURES

PNEUMATIC ACTUATORS

- Rack and pinion design
- Spring return or double acting
- Open and closed adjustment stops
- True NAMUR accessory mounting
- Visual indicator

ELECTRIC ACTUATORS

- 120VAC, 220VAC, 24VAC, 12VDC, 24VDC
- NEMA 4 and NEMA 7
- Manual override
- Visual indicator

NOTE: Maximum temperature rating for standard actuators is 150°F (electric) and 180° (pneumatic). Special seals or heat extensions are available for high temperature service

All Valves Are 100% Electronically Tested At 80 Psi In Both The Open And Closed Positions

Motorized ball valves factory preset "Normally Open".
(If valves are required to be normally closed, please note on purchase order.)

NOTE: For options/upgrades, see Options List. Specifications subject to change without notice.

FRS Manifold

Specification Sheet

PRODUCT NUMBER:

N/A (Product standard on every multi-tank (MTU) system)

PRODUCT DESCRIPTION:

A factory assembled manifold with two (2) motorized ball valves designed to receive and return fuel from multiple lines, converge them into one line to deliver through the FRS system and diverge them back to the tanks.

Note: The manifold may be expanded to a 4-tank installation (2 valves per tank).

Motorized ball valves factory preset "Normally Open".
(If valves are required to be normally closed, please note on purchase order.)

PRODUCT FEATURES:

Product Number	N/A
Product Name	Multi-tank Manifold
Capacity	2 to 4 tank capacity



NOTE: For options/upgrades, see Options List. Specifications subject to change without notice.