



INSTALLATION, OPERATION & MAINTENANCE MANUAL

FRS 660

Complete NEMA 4 UL 508A

Automatic Fuel Recirculating Systems



All RCI Systems are cycle and leak tested for a minimum of 2 hours prior to shipment.



TABLE OF CONTENTS

PRODUCT RUN TIME CHART	3
OVERVIEW – BASIC SYSTEM COMPONENTS	4
GENERAL SPECIFICATIONS.....	5
SYSTEM COMPONENTS	6
OPTIONAL UPGRADES.....	7
PRIMARY INSPECTION.....	7
INSTALLATION	8
Mounting	8
Electrical	8
Plumbing.....	8
IMPORTANT INSTALLATION PRECAUTIONS	8
PRIMING THE SYSTEM.....	9
INITIAL START-UP	9
OPERATION.....	9
Pump Operation	9
Fuel Line Leak	9
Stabilizing and Optimizing Fuel Quality	10
MAINTENANCE.....	11
Preventative Maintenance	11
Servicing water separator	11
Servicing secondary filter.....	12
SPECIFICATION SHEETS	13
115 VAC Actuator & Ball Valve.....	13
FRS Manifold.....	15
TROUBLESHOOTING.....	16
WARRANTY	17
Conditions of Sale	17
Fuel Recirculating Systems Warranty.....	18
Fuel Recirculating Systems Extended Warranty	18
TECHNICAL SUPPORT	19
FRS 660 SYSTEM IDENTIFICATION.....	19



PRODUCT RUN TIME CHART

Fuel Recirculation System FRS 660

Total Run Time in Hours per Month by Tank Capacity

Tank Capacity (Gallons)	FRS 660-5 (5 gpm/300 gph)	FRS 660-11 (11 gpm/660 gph)	FRS 660-25 (25 gpm/1500 gph)	FRS 660-50 (50 gpm/3000 gph)	FRS 660-60 (60 gpm/3600 gph)	FRS 660-150 (150 gpm/9000 gph)
150	1					
250	1					
500	3					
1,000	5					
2,000	10					
3,000	15					
4,000	20					
5,000	25					
6,000	30					
7,000	35					
8,000	40					
9,000	45	20				
10,000	50	23				
12,000	60	27				
14,000	70	32				
16,000	80	36				
18,000	90	41				
20,000	100	45	20			
25,000	125	57	25			
30,000	150	68	30			
35,000	175	80	35			
40,000	200	91	40	20		
45,000		102	45	23		
50,000		114	50	25	21	
60,000		136	60	30	25	
70,000		159	70	35	29	
80,000		182	80	40	33	
90,000		205	90	45	38	
100,000			100	50	42	17
150,000			150	75	63	25
200,000			200	100	83	33
250,000				125	104	42
500,000					208	83
1,000,000						167



NOTES:

- Run Times are based upon the tank filled to full capacity.
- FRS Systems can be programmed to operate for one complete cycle or divided into segments spanning several days.
- Consideration should be given for the operation of the system during time periods when “trained” Maintenance Staff are present in case an alarm condition occurs, such as high water.

OVERVIEW – FRS 660 (5, 11 & 25 gpm) NEMA 4 UL 508A BASIC SYSTEM COMPONENTS FOR SINGLE AND MULTI-TANK UNITS

1. **NEMA 4 UL 508A** Rated System Enclosure with Hinged Door(s) and Industrial Powder Coating (white)
2. **UL** Listed Touch Screen Display for System Status Security Enabled Programming.
3. **UL** Listed Audible Alarm
4. **UL** Listed Visual Alarm with Reset Button
5. **UL** Listed Operator Interface HOA Switch
6. Y Strainer (1) (1/2", 1", 2" or 3")
7. Handle with Keyed Lock
8. Floor Mounting Feet
9. Wall Mounting Hinges
10. **NEMA 4X** Rated Operator Interface Compartment
11. **NEMA 4X** Rated **ELECTRONICS** compartment (PLC, Manual Starter, Motor Contactor) (Cover Not Shown)
12. Air Purge Valve (Manual)
13. RCI Purifier (7 or 40 gpm.)
14. Supply Line Check Valve (.5" or 1" dia.)
15. Unions (3) (.5" or 1" dia.)
16. Priming Tee (.5" or 1" dia.)
17. Supply Line Ball Valve (.5" or 1" dia.)
18. **NEMA 4** Door Seals
19. Internal Locking Mechanism
20. O&M Manual Holder
21. Positive Displacement Pump (5, 11 or 25 gpm.)
22. TEFC Pump Motor (1/3, 1 or 2 HP)
23. Catch Basin with Drain Plug
24. Leak Sensor (1/8" Alarm)
25. Manual Water Drain Valve
26. Water Sensor
27. **NEMA 4X** Rated Customer Interface Compartment (Cover Not Shown)

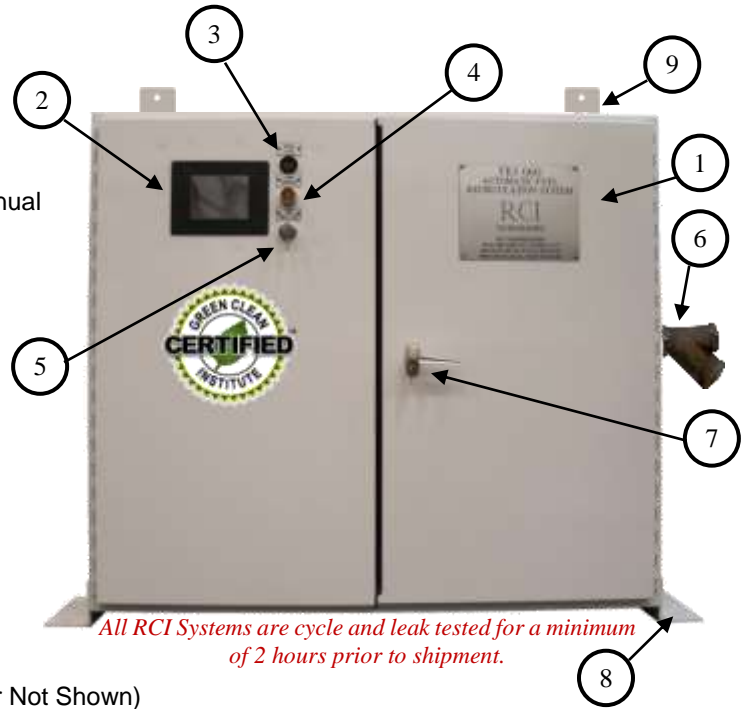

- A. **ELECTRICAL INPUT**
 - a. STANDARD (110 or 220 VAC, 60 Hz, 1 Ph)
 - b. OPTIONAL (208/308/480 VAC, 3 Ph)
- B. **OUTPUTS**
 - a. STANDARD ALARM COMMUNICATION (4 Relays) – Leak Detection, Water, Pressure, Summary
 - b. STANDARD CONTROL RELAYS – for multiple tanks Motorized ball valves. **Motorized ball valves factory preset normally "OPEN". (If valves are required to be normally closed, please note on purchase order.)**
 - c. OPTIONAL COMMUNICATOR - Modbus RTU or Ethernet Communication
28. Pressure Sensor (Factory Set At 75 psi)
29. Return Line Ball Valve (.5" or 1" dia.)
30. Micro-organism Decontamination Unit

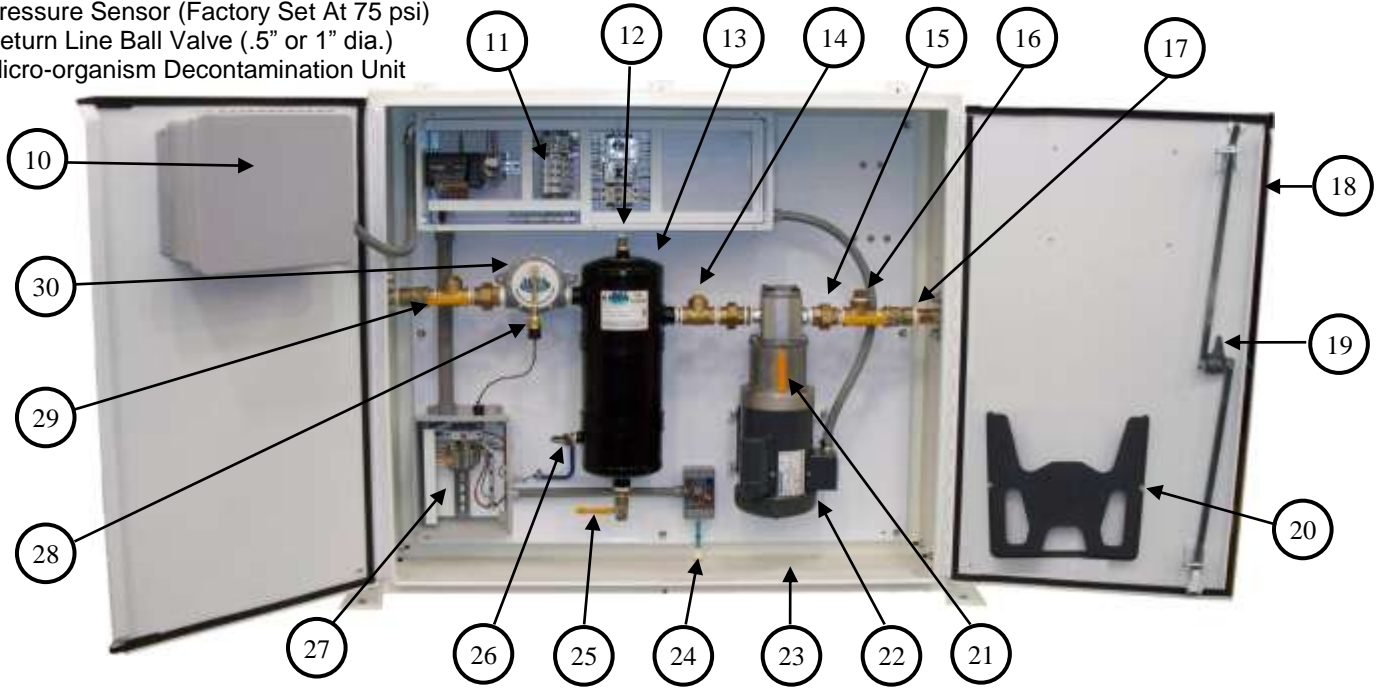

GENERAL SPECIFICATIONS

FRS 660-5

Flow Rate	5 gpm / 120 gph
Outline Dimensions (Enclosure)	36" x 36" x 12" (H x W x D)
System Weight	approx. 275 lbs
Operating Temperature	32 - 104° F; 0 - 40° C
Electrical	115-208-230 V / 60 Hz single phase
Pump	Gear Pump
Purifier	FP 800 – RCI Universal Fuel Purifier
Suction capability (primed)	20 ft vertical or 100 ft. horizontal lift (lines >1", primed)
Motor	1/3 HP, single phase, continuous duty, thermally protected
Timer	PLC (standard)
Inlet	½" NPT male port
Outlet	½" NPT male port
Y Strainer:	(1) 1/2"
Max. Fluid Viscosity	29 cSt

FRS 660-11

Flow Rate	11 gpm / 660 gph
Outline Dimensions (Enclosure)	42" x 48" x 12" (H x W x D)
System Weight	approx. 500 lbs
Operating Temperature	32 - 104° F; 0 - 40° C
Electrical	115-208-230 V / 60 Hz single phase
Pump	Gear Pump
Purifier	FP 1000 – RCI Universal Fuel Purifier
Suction capability (primed)	20 ft vertical or 100 ft. horizontal lift (lines >1", primed)
Motor	1 hp single phase, continuous duty, thermally protected
Timer	PLC (standard)
Inlet	1" NPT male port
Outlet	1" NPT male port
Y Strainer:	(1) 1"
Max. Fluid Viscosity	29 cSt

FRS 660-25

Flow Rate	25 gpm / 1500 gph
Outline Dimensions (Enclosure)	48" x 42" x 12" (H x W x D)
System Weight	approx. 650 lbs
Operating Temperature	32 - 104° F; 0 - 40° C
Electrical	115-208-230 V / 60 Hz single phase
Pump	Gear Pump
Purifier	FP 1000 – RCI Universal Fuel Purifier
Suction capability (primed)	20 ft vertical or 100 ft. horizontal lift (lines >1", primed)
Motor	2 hp single phase, continuous duty, thermally protected
Timer	PLC (standard)
Inlet	1" NPT male port
Outlet	1" NPT male port
Y Strainer:	(1) 1"
Max. Fluid Viscosity	29 cSt



Note: The FRS 660 is designed to meet environmental standards for safe operation. (NOT for use with fluids that have a flash point below 100° F (38°C), e.g.: gasoline, alcohol, ...)

SYSTEM COMPONENTS

Control and Safety Devices

- Complete NEMA 4 UL 508A Systems
- PLC Control and Customer Interface
- Pump control switch (Auto-Off-Manual), weatherproof, key operated
- Power available indicator
- Pump running indicator
- Inlet and outlet shut off ball valves. **Motorized ball valves factory preset normally "OPEN".** *(If valves are required to be normally closed, please note on purchase order.)*
-
- Pressure relieve valve
- Swing type check valve on the discharge line
- Cabinet leak sensor and alarm (pump shutoff)
- Water indicator and pump shutoff
- Optional high vacuum indicator and pump shutoff
- Optional secondary filter high pressure indicator and pump shutoff
- Control power fuses
- Pump motor starter with 15A single-pole circuit breaker and 30A DP contactor

Pump / Motor / Coupling:

- Positive displacement gear pump
Aluminum housing Steel gears
Hardened steel shaft Mechanical shaft seal Priming tee
- Motor
1/3 to 2 HP / 115 VAC / 60Hz single-phase
Open drip proof construction
Integral overload protection
- Flexible, self-aligning shaft coupler

Magnetic Fuel Decontamination Unit

- Magnetic Fuel Decontamination Unit

Primary Filter / Water Separator

- Drain valve on the bottom

Optional Filter

- Spin-on type with proper element
- Optional pressure gauge for spin-on filter

Weatherproof NEMA 4 UL 508A enclosure with hinged/latch accessible double front doors

- 16-gauge steel construction with welded seams and flanged doors
- Containment basin in bottom
- Lockable latches
- Bottom and side flanges for pad or wall mounting
- Finished in white industrial powder coating



OPTIONAL UPGRADES

ALARM

- Automatic water drain into 15 gallon container w/high level alarm. (Container supplied by other)

FILTER

- 2 – 30 Micron Spin-On Filter.
- Micron Spin-On Filter 1/2" NPT w/gauge.
- Micron Spin-On Filter 1" NPT w/gauge.

HEATER

- Purifier heater.
- Strip heater for controller
- Thermostatically controlled system heater (touch pad, controller purifier.)

ELECTRICAL

- Ethernet - PLC module, operator interface & 5 port.
- Ethernet - field retrofit operation PLC module, operator interface & 5 port.
- Main disconnect breaker w/rotary handle (250) 1230 (UL 508A w/42k interrupt capacity.)
- Main disconnect breaker w/rotary handle (480) 1230 (UL 508A w/42k interrupt capacity.)
- Non-fused main disconnect switch w/rotary handle.
- MODBUS RTU output.
- Secondary containment interface.
- Upgrade to 480VAC, 3 phase power.
- 208 Volt - 3 Phase - 60 Hz.
- 230 Volt - 3 Phase - 60 Hz.
- 380 Volt - 3 Phase - 50 Hz.
- 480 Volt - 3 Phase - 60 Hz.

PRIMARY INSPECTION

Upon arrival, the FRS 660 Fuel Recirculating System and accessories must be visually inspected before installation. Shipping and handling may cause physical or electrical problems.

Checklist:

- If the packing crate shows signs of damages, take photographs of the damaged crate prior to opening and notify shipper in writing of possible damages.
- Inspect the FRS 660 cabinet for damage. Check the entire outside of the cabinet for damage that could indicate internal mechanical or electrical problems.
- Check main locking handle, door and hinge operation.
- Check pump/motor hardware for tightness. Rotate motor shaft by hand and check for smooth operation.
- Check pump/motor coupler for proper alignment and spacing. The coupler should have approximately 1/8" clearance between coupler halves. If this clearance is reduced or the pump and motor are not properly aligned excessive noise and pump/motor wear will occur.



INSTALLATION



! IMPORTANT ! It is recommended that only qualified, experienced personnel, familiar with this type of equipment, who have read and understood all the instructions in this manual should install, operate and maintain the system.

MOUNTING

The FRS 660 is a totally enclosed system and should be wall or pad mounted on a hard, level surface. Use provided mounting holes/feet for proper fastening. This weatherproof unit is designed for well-ventilated indoor or outdoor use and should be located as close to the fuel tank as possible.

ELECTRICAL



! WARNING ! To avoid the risk of electric shock make sure that the power supply to the system is disconnected and ensure that the system is at zero volts, before working on any of the system's electrical parts.



! WARNING ! NEMA 4 integrity (all connections are to maintain NEMA 4 UL 508A integrity.)

Make sure that the systems power requirements and rated voltage match your electrical system (See wiring diagram) The FRS 660 may only be connected to properly grounded power sources for operator safety. Connect all components to the ground studs provided as shown in the electrical drawings.

Multiple Tank Units (MTU) are available in the following:

- 1) **HARDWARE:** Each valve requires seven (7) leads utilizing 18 or 20 gage wire.



! WARNING ! The whole system (Enclosure, doors, plumbing, motor, electric sub panel) must be properly grounded for operator safety.

Depending on the length of the run and the (FAL) Full Amp Load of the specific system, all wiring must be done to meet local code.

PLUMBING



! WARNING ! When making plumbing connections to the FRS unit, it is imperative to use a take up wrench to prevent loosening of interior plumbing.

Use proper quality approved fuel line materials. The pick-up tube/line(s) should originate from the lowest point of the tank (to remove all water) and should be connected directly to the system's "PUMP INLET" port located on the right hand side of the enclosure. **It is recommended to install an oversized, low restriction foot valve to keep the system primed,** especially if the "PUMP INLET" port of the system is located above the lowest possible fuel level in the tank. A priming tee should be installed on the highest point of the suction line to be able to easily prime the system.

The return line(s) should be plumbed to the "PUMP OUTLET" port (on the left side of the system) and enter the tank as far as possible from the pick-up tube close to the tank bottom. Multiple suction and/or return lines may be connected to a manifold outside the FRS 660.

The system capabilities are 20 ft suction (vertical) and 100 ft horizontal lift, when connected to piping of ½" ID to 1" ID, depending on the flow rate of your system. For continuous optimal performance, make sure suction and discharge lines are free and that nothing is blocking the flow of fuel.

IMPORTANT INSTALLATION PRECAUTIONS

The suction line of the system should be independent and separate, with a foot valve and priming "T" installed to facilitate and maintain priming.

The return line should also be an independent and separate line returning to the tank.

Note: If any of the FRS 660 system's fuel lines are used in combination with the engine's fuel system, then the appropriate valving should be installed and the FRS 660 should be disabled during engine operation (use the provided dry contacts "pump shut down" as shown in the electrical drawing and run system only in "AUTO" mode).

PRIMING THE SYSTEM

The pump supplied with the FRS 660 is NOT automatically self-priming.



! WARNING ! If the pump is allowed to run without fuel, pump damage will occur and voids the warranty.

The pump head of the FRS 660 unit is shipped from the factory filled with Diesel #2 to facilitate system priming. This will not eliminate the necessity to prime the system at the pump and at the primary filter/water separator. The FRS 660 is primed by using the priming tee on the inlet side of the pump. Also if your system has an optional spin-on filter, the filter as well as the suction line will need to be completely filled with fuel prior to the initial system start-up.

PRIMING PROCEDURE:

1. Ensure the pump is filled with #2 Diesel fuel.
2. Ensure that all ball valves are in the open position. **Motorized ball valves factory preset normally "OPEN".** *(If valves are required to be normally closed, please note on purchase order.)*
- 3.
4. If the "PUMP INLET" port of the FRS 660 is located below the fuel level in the tank close the inlet ball valve.
5. Open the priming tee, fill the line with fuel, close the tee (for tanks situated on a lower level than the FRS 660, it is recommended that a foot valve is installed at the fuel tank to maintain prime in your system).
6. Open the fill plug located on top of the fuel water separator and fill with fuel.
7. If the system is equipped with an optional spin-on filter, remove filter fill with fuel and replace.
8. Make sure to completely fill suction line to its highest point with fuel, in particular when the suction line exits the tank top and the FRS 660 is located below that level.
9. Switch on the pump and observe fuel flow.

INITIAL START-UP

REMINDER: All RCI Technologies FRS 660 Systems come standard with Touch Pad PLC Communications.

MANUAL

Upon initial system power up, the **TOUCH SCREEN** will prompt you as follows:

- RCI Power Up** Screen (as shown in the manual).
- Warning** Screen (as shown in the manual).
 - o Once the operator presses **OK**, the system is ready to run.
- The system will begin pumping once the **SYSTEM H/O/A** switch, located on the front of the enclosure, is switched onto the **HAND** (manual) position.

Note: If the system does not begin pumping, you must access the alarm screen and clear all alarms prior to running system. Clear alarms as follows:

- Press the **SYSTEM ACKNOWLEDGE** button, located on the front of the enclosure, if it is illuminated.*
- From the **SYSTEM OVERVIEW** screen (as shown in the manual) press **VIEW ALARMS**.*
- From the **Alarm** screen (as shown in the manual) press **CLEAR ALL**.*
- The system should begin pumping.*

AUTO

- In order to run the system in the **AUTO** mode turn the **SYSTEM H/O/A** switch, located on the front of the enclosure, to the **AUTO** position.
- From the **Main Menu** screen (as shown in the manual) press **AUTOMATIC TIMER SETUP**.
- From the **Automatic Timer** screen (as shown in the manual) program the required ON and OFF time to the required DAY.

*Note: For additional explanation as to how to program your automatic times press **HELP** from the **Automatic Timer** screen.*

Note: If any of the above described alarm test procedures fail or if any alarm trip value deviates immediately contact RCI Technologies.

OPERATION



! WARNING ! Do not fill with gasoline. This System is not meant for use with gasoline nor with other flammable liquids having a flash point less than 100°F. The use of gasoline or any other flammable liquids at a temperature exceeding their flash point, presents an immediate explosion and fire hazard.



! WARNING ! Do not use the FRS 660 at a temperature exceeding the flash point of its contents.

PUMP OPERATION

Apply control power to unit. Place the main disconnect breaker switch in the “ON” position.

Automatic:

Place the “PUMP SELECTOR SWITCH” (located outside of the left door panel) in the “AUTO” position. Pump will start and stop at designated time interval.

Manual (Override):

Place the “PUMP SELECTOR SWITCH” in the “RUN” mode. The pump motor will run until the switch is returned to the “OFF” or “AUTO” mode positions or until an alarm or pump overload has been tripped.

FUEL LINE LEAK

If fuel is detected in the system retention area, the float switch will activate the fuel leak alarm triggering an alarm register on the alarm log and turning “OFF” the pump. The pump motor will shut off and remain locked out of operation until the leak has been corrected. Before removing the spilled fuel from the basin, turn the key switch to the “OFF” position.

Always make sure to find the cause of the leak and correct it. After removing the spilled fuel and allowing the leak switch to return to its normal position, the key switch can be returned to the “AUTO” or “RUN” mode.

Note: Disposal of fuel should be done in accordance with Federal, State and Local regulations.

STABILIZING AND OPTIMIZING FUEL QUALITY

We recommend treating the fuel with the Bell Performance’s DEE-ZOL LIFE. This will enhance and accelerate the tank cleaning process by breaking down and dissolving existing tank sludge.

Product Details:

DEE-ZOL LIFE – Formulated to prevent the problems associated with fuel aging and breakdown resulting from storage of fuel for long periods of time. Reduces the formation of harmful sludge and sediments in stored diesel fuel. Also reduces filter plugging problems associated with shellac and varnish deposits formed during fuel storage. Addition of DEE-ZOL LIFE to diesel fuel enables the fuel to meet and/or exceed U.S. Military and ASTM Storage Standards.

Recommended Ratios:

- 1 quart to 500 gallons of diesel fuel.
- 1 gallon treats 2,000 gallons of fuel.
- Always add DEE-ZOL LIFE to fuel tank prior to filling.
- If added to existing fuel, recirculation (or mixing) required.

Note: In cases of severe tank contaminant build-up and high water level in bottom, it is recommended to have the tank professionally cleaned (polished) before initial use of an FRS system.



MAINTENANCE



! IMPORTANT ! It is recommended that only qualified, experienced personnel, familiar with this equipment, who have read and understood all the instructions in this manual should install, operate and maintain the system.



! IMPORTANT ! Always disconnect the system from the electric power supply before working or servicing it. Do not proceed with any maintenance unless the pressure or vacuum has been released, the system has been allowed to reach ambient temperature and all fluids have been drained.

PREVENTATIVE MAINTENANCE

The FRS 660 Fuel Recirculating System should be visually inspected and tested every six months according to the procedure below during light duty cycles. Monthly inspections are recommended for systems that are being used in excess of an average of 8 hours day and five days a week.

- Prior to performing the maintenance procedure ensure that:
 - 1) The user supplied remote circuit breaker is in the “Off” position.
 - 2) That all sources of power are isolated from the unit.
 - 3) Proceed only after this has been verified.
- Check main locking latch, door and hinge for proper operation. Lubricate as needed.
- Check cabinet mounting hardware at feet and wall mounting flange. Tighten as necessary.
- Check pump/motor hardware for tightness.
- Rotate shaft by hand and check for smooth operation. Check pump/motor coupler for proper alignment and spacing. The coupler should have approximately 1/8" clearance between coupler halves. If this clearance is reduced or the pump and motor are not properly aligned, excessive noise and pump/motor wear will occur. Loosen pump motor mounting hardware to realign motor/coupler. Loosen one end of pump coupler to adjust for necessary coupler clearance.
- Check all electrical terminals in the customer interface panel for tightness.
- All pumps and motors are permanently lubricated and do not require any lubrication or maintenance.
- Check all plumbing joints for leaks. Tighten fittings and joints as necessary.
- Inspect separator and any optional filters.
- With breakers and power turned on again and pump running **check all alarms** for proper operation:
 - 1) Manually raise float switch located in retention basin. Pump should immediately turn off. Reset alarm via touch pad.
 - 2) Slowly close outlet ball valve. At 75 PSI pump should turn off. Reset alarm via touch pad.
 - 3) Ground fuel purifier probe. Pump should immediately turn off and “SERVICE WATER SEPARATOR” should illuminate. Reset alarm via touch pad.

Note: If any of the above described alarm test procedures fail or if any alarm trip value deviates immediately contact RCI Technologies.

SERVICING WATER SEPARATOR

If the water level in the fuel water separator reaches a certain level in the bowl, the water sensor will trigger the alarm “SERVICE WATER SEPARATOR” and shut off the pump. The signal indicates that it is time to drain the bowl on the water separator.

Draining water from the primary filter/water separator:

1. Turn the HOA switch to the “OFF” position.
2. Place a fuel waste container below the drain valve on the bottom of the purifier.
3. Press the brass air purge button on the top of the purifier.
4. Open the drain valve.
5. Close after approximately 1 second.
6. After approximately 10 seconds, reopen the drain valve, repeat as needed until clean fuel is observed.
7. Close after visible sediment, particles and water have been drained from the separator.
8. Prime the purifier by pressing the push button air purge valve located on the top of the fill plug.
9. Restore HOA switch to “AUTOMATIC”.
10. Restore all alarms via touch pad.

Your system is now ready to resume normal operation

Note: Disposal of fuel should be done in accordance with Federal, State and Local regulations.

SERVICING SECONDARY FILTER

Your FRS 660 System may have a secondary filter option.

Clogging filter elements restrict the flow of fuel and the system's pressure gauge will indicate a pressure drop. The gauge is mounted on top of the secondary filter. At a pressure drop of 25 PSI (red dial area of the gauge) the pump will automatically shut off and activate the "SERVICE SECONDARY FILTER" alarm. The signal indicates that it is time to change the filter element.

Spin on final filter available:

1. The standard 2 to 30 micron filters.

Changing the secondary filter:

1. Turn HOA switch to "OFF" position.
2. Close the inlet and outlet ball valves
3. Place an appropriate container underneath the filter.
4. Remove old spin on filter by turning the cartridge counter clock wise seen from the bottom of the cartridge.
5. Apply a film of lubricating oil to the gasket of the new filter. Screw the new filter canister to the filter head until the gasket is tight and secure (an additional 1/2 to one turn after the filter makes contact with the gasket).
6. Open the inlet and outlet ball valves
7. Restore HOA switch to "HAND" position. Pump should start.
8. Return the pump selector switch to "AUTO".
9. Check for leaks when re-starting and pressurizing the system.
10. Clear alarm history, via touch pad.

Your system is now ready to resume normal operation

Note: Disposal of fuel should be done in accordance with Federal, State and Local regulations.



! WARNING ! Some fuels may have been treated with biocides. Biocides are extremely toxic and may enter the body through the skin. It is recommended to use adequate protection and avoid skin contact with biocide-treated fuels.



115 VAC Actuator & Ball Valve Specification Sheet

PRODUCT NUMBER:

1001

PRODUCT DESCRIPTION:

The 115V Actuator is used on brass motorized ball valves rated at 600 WOG (1/2" for the 5GPM and 11GPM systems, 1" on the 25GPM systems). It is constructed with a NEMA 4 protective cover.

PRODUCT FEATURES:

Product Number	1001
Product Name	115VAC ACTUATOR AND BALL VALVE
Output Torque	100 inch pounds
Cycle Time	2.5 sec/90°
Duty Cycle	75%
Standard Motor	115VAC/60Hz/1ph
Standard Enclosure	NEMA 4
Enclosure Material	Aluminum
Enclosure Coating	Thermal bonding polyester powder
Temperature Rating**	-40°F to +150°F
Thermal Overload Protection	Standard
Manual Override	Standard (omit on NEMA 7)
Lock Rotor Current	0.55 amps
Switches	15A, 1/2 HP 125 250VAC/0.5A/125VDC
Weight	5 pounds

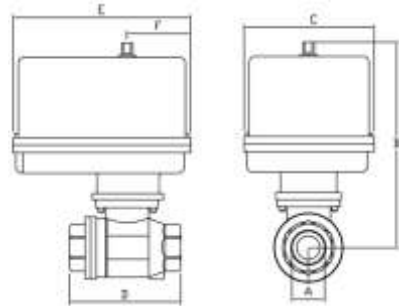

**IP-Series 2-Piece Brass Ball
Valves**

Section	Ball Valve Size		
	1/2"	1"	1 1/2"
A	1.21	1.21	1.21
B	6.13	6.57	8.29
C	4.00	4.00	4.22
D	2.64	3.35	4.13
E	5.63	5.63	5.63
F	2.31	2.31	2.43
ACT.	100E	100E	200E
WT.	5.82	6.35	10.17

PART #	NAME	MATERIAL	OPTIONAL MATERIAL	QTY
1	BODY	BRASS UNI 5705-65	N/A	1
2	ENDS	BRASS UNI 5705-65	N/A	2
3	BALL	BRASS UNI 5705-65 CHROME PLATED	316SS	1
4	SEAT	TFE	N/A	2
5	BODY SEAL	VITON	N/A	2
6	STEM SEAL	TFE	N/A	1
7	BODY O-RING	VITON	N/A	2
8	STEM O-RING	VITON	N/A	1
9	STEM NUT	BRASS UNI 5705-65	316SS	1
10	STEM	BRASS UNI 5705-65	316SS	1

VALVE FEATURES

- Full port brass valve
1/4" through 4"
- Optional stainless
Steel ball & stem
1/4" through 2"
- TFE® seats and seals
- Viton® body o-rings
- ISO mounting pad
- Blowout proof stem
- CE rated

PRESSURE RATING
600 WOG

TEMPERATURE RATING
+297°F Maximum

ACTUATOR FEATURES

PNEUMATIC ACTUATORS

- Rack and pinion design
- Spring return or double acting
- Open and closed adjustment stops
- True NAMUR accessory mounting
- Visual indicator

ELECTRIC ACTUATORS

- 120VAC, 220VAC, 24VAC, 12VDC,
24VDC
- NEMA 4 and NEMA 7
- Manual override
- Visual indicator

NOTE: Maximum temperature rating for standard actuators is 150°F (electric) and 180° (pneumatic). Special seals or heat extensions are available for high temperature service

All Valves Are 100% Electronically Tested At 80 Psi In Both The Open And Closed Positions

Motorized ball valves factory preset normally "OPEN".
(If valves are required to be normally closed, please note on purchase order.)

NOTE: For options/upgrades, see Options List. Specifications subject to change without notice.

FRS Manifold Specification Sheet

PRODUCT NUMBER:

N/A (Product standard on every multi-tank (MTU) system)

PRODUCT DESCRIPTION:

A factory assembled manifold with two (2) motorized ball valves designed to receive and return fuel from multiple lines, converge them into one line to deliver through the FRS system and diverge them back to the tanks.

Note: The manifold may be expanded to a 4-tank installation (2 valves per tank).

Motorized ball valves factory preset normally "OPEN".
(If valves are required to be normally closed, please note on purchase order.)

PRODUCT FEATURES:

Product Number	N/A
Product Name	Multi-tank Manifold
Capacity	2 to 4 tank capacity



NOTE: For options/upgrades, see Options List. Specifications subject to change without notice.



TROUBLESHOOTING

No fuel delivery

1. Pump does not run
2. Pump is not primed
3. Fuel supply line blocked
4. Lift is too high
5. Air leak in fuel supply to pump
6. Pump rotation direction incorrect
7. Intake or outlet valve closed
8. Check valve installed backwards

Insufficient fuel delivered

1. Air leak at inlet
2. Defective pressure relief valve or check valve
3. Lift too high
4. Pump worn
5. Inoperative foot valve
6. Piping improperly installed or dimensioned
7. Fuel water separator plugged

Rapid pump wear

1. Pipe strain on pump causing bind
2. Worn pump/motor coupler
3. Pump has been run dry or with insufficient fuel
4. Plumbing on inlet side not appropriately dimensioned

Alarm “SERVICE PRIMARY FILTER” comes on with clean or new filter element installed

1. Restriction in plumbing on inlet side too high
2. Lift too high
3. Inoperative foot valve
4. Inlet ball valve not fully open
5. Suction line clogged

Alarm “SERVICE SECONDARY FILTER” comes on with clean or new filter element installed

1. Restriction in plumbing on discharge side too high
2. Head (lift) on discharge side too high
3. Check valve stuck or defective
4. Outlet ball valve not fully open
5. Discharge line clogged

Pump requires too much power

1. Air in plumbing lines
2. Liquid too viscous
3. Bent pump shaft, binding rotor
4. Misalignment of pump/motor coupler

Noisy operation

1. Insufficient fuel supply
2. Air leaks in the inlet pipe
3. Air or gas on the suction side
4. Pump and motor out of alignment
5. Worn out spider coupling
6. Pump coupler out of balance

Pump requires frequent re-priming

1. Inoperative foot valve
2. Inoperative check valve
3. Inoperative Motorized ball valve (optional)
4. Pump cavitations
5. Plumbing air leaks
6. Lift too high
7. Leaking pump seal

Motor does not turn or turns intermittently

1. Control power not available
2. Motor thermal overload condition
3. Pump failed and seized
4. Motor failure

Pump leaks fuel

1. Loose pump plumbing fittings
2. Worn pump shaft seal
3. Pump pressure relief valve failure
4. Fuel leak elsewhere and fuel dripping or running towards the pump
5. Excessive head from overhead storage tank
6. Worn pump O-rings or seals



CONDITIONS OF SALE

The following conditions apply without exception unless such exception is made in writing and signed by an officer of RCI Technologies. RCI Technologies will, at its option, sell or rent technical industrial equipment or parts thereof or material only on condition that buyer assumes responsibility for correct specification, storage, installation, field adjustments when normally required, testing and appropriate training of users by technically competent personnel before release to user and that may malfunction or failure of RCI Technologies supplied material will be reported to RCI Technologies immediately and that no back-charges of any nature will accrue to RCI Technologies, without the express written consent of RCI Technologies.

QUOTATIONS

Unless specifically stated otherwise, price quotations are based on standard pricing, handling, delivery and warranty. Substantial alterations in details or intent of RCI Technologies' quotation on buyer's purchase order, subject buyer to additional charges based on increased cost incurred by RCI Technologies. Written quotations are firm for 60 days unless otherwise noted. Acceptance of orders based on oral quotes, published literature or written quotations older than 60 days are subject to approval by an officer of RCI Technologies. Delivery dates are the best estimates as of date of issue.

PRICES

All prices are f.o.b. San Dimas, California, with buyer paying all freight costs, unless allowed in written quotation. Prices and other published data are for reference purposes only and do not imply availability of product. Prices are subject to change without notice and prices in effect at the time of shipment will apply to new orders and unreleased existing orders unless otherwise quoted in writing.

MINIMUM BILLING

A minimum billing of not less than \$50.00 will apply to all orders. Minimal fees to offset in part extra costs incurred during order entry process, special services as ordered by customer, shipping processes and collection effects will be charged where applicable.

TAXES

Published or quoted pricing does not include any federal, state or local taxes. Buyer should report any federal, state or local taxes as may be required by local law.

PENALTY CLAUSES

Unless specifically accepted in writing by RCI Technologies, price quotations do not include participation by RCI Technologies in any penalties or damages incurred by buyer.

ACCEPTANCE OF ORDERS AND CONTRACTS

All orders must be bonafide contracts detailing complete description of material ordered, including technical specifications as quoted by RCI Technologies, price, terms, delivery, shipping instructions, etc. RCI Technologies' failure to object to any provisions contained in buyer's order or any other communications shall not constitute a waiver of RCI Technologies' terms and conditions not acceptance of such provisions. No order shall be considered accepted unless acknowledged in writing by RCI Technologies.

TERMS OF PAYMENT – PURCHASED MATERIAL

Net cash U.S. funds 30 days from date of invoice, which shall be the same as date of shipment from our factory to approved open account customer. All other orders are cash in advance or COD. Material ordered to ship on a given date and later ordered by buyer to be held for later shipment will be invoiced on date shipment originally scheduled or on date material becomes available for shipment, whichever occurs later and terms of payment will apply from that invoice date. No cash discounts are allowed.

TERMS OF PAYMENT – RENTAL EQUIPMENT OR FIELD SERVICE

Payable upon receipt of invoice in U.S. funds to approved open account customers. In other cases, payment by cash in advance, COD or security deposit.

SERVICE CHARGES

Service charges apply from 31st day after invoice date. Failure to pay such charges as billed may result in suspension of open account terms.

CANCELLATION

Upon acceptance by RCI Technologies your order will be entered for production and will not thereafter be subject to cancellation or deferment of delivery schedule without written consent from RCI Technologies. Any expenses incurred by RCI Technologies, due to cancellation of any order, or the extra expense of deferment of a delivery schedule, will be borne by the customer.

PACKING AND MARKING

Prices include our standard packing and marking for domestic shipment within the continental U.S. Additional expenses incurred for special packing or marking as specified by buyer will be paid by the buyer. No allowance in lieu of packing will be made if buyer accepts material unpacked at our factory or authorized service station.

SHIPPING WEIGHTS

Published shipping weights are approximate and are provided only for estimating freight costs.

SHIPMENTS

Shipments will be made best way surface unless otherwise specified by buyer. Responsibility for lowest cost and fastest means shipping methods is buyer's and details are to be specified in the buyer's purchase order. RCI Technologies' responsibility ceases when the carrier signs for and accepts shipment and claims for non-delivery of material or damage should be filed with carrier by buyer.

RETURNING MATERIAL

Written authorization to return material for credit or repair or replacement must be obtained from RCI Technologies. Such returns are subject to restocking, exchange or repair charges with all transportation charges paid by buyer and are subject to acceptance by RCI Technologies. RCI Technologies, at its option, will apply credited amounts to buyer's account, current or future balances, or issue cash refund.

DRAWING

One copy of standard drawings, wiring diagrams and instruction manual conforming to RCI Technologies standard practices will be furnished per unit purchased at no charge. Prices quoted upon request for special drawings or additional copies of standard drawings and instruction manuals.

WARRANTY

RCI Technologies warrants new industrial equipment or parts or material to be the kind and quality described in RCI Technologies' specifications and to be free from defects in material or workmanship under proper conditions of application and use, for a period of 12 months.





FRS PRODUCT WARRANTY

RCI Technologies warrants the industrial electrical control, test and accessory equipment and parts and accessories thereof, to be the kind and quality described in RCI Technologies' specifications and to be free from defects in material or workmanship under normal service. Its obligations under this warranty being limited to repairing or replacing, at its option, any part or parts which shall, within twelve (12) months from date of shipment from its factory, as indicated by serial date code on the nameplate or sales records, be returned to RCI Technologies or an authorized RCI Technologies repair station, with transportation costs prepaid, and which its examination shall disclose to its satisfaction to have been thus defective.

The provisions of this warranty shall not apply to any equipment, part or accessory which:

- a) Has been improperly specified by buyer;
- b) Has been improperly stored or handled prior to placing in service;
- c) Has been improperly mounted or connected;
- d) Has been improperly operated within specifications stated on its nameplate, label or placard;
- e) Has not been properly maintained;
- f) Parts supplied by buyer for inclusion in finished equipment are not covered by this warranty;
- g) Components or assemblies specified by buyer with no substitution permissible that are not normally used by RCI Technologies.

RCI Technologies reserves the right to reject warranty claims of any kind against assembled equipment, parts or material for which RCI Technologies has not received payment in full.

Should buyer, at his own risk, elect to replace defective equipment or parts in the field rather than return equipment to RCI Technologies' factory or authorized repair station, RCI Technologies will supply and invoice parts at normal prices upon receipt of buyer's bonafide purchase order. Defective equipment or parts returned for in-warranty crediting in exchange for replacements parts must be returned within 45 days from date of shipment of replacement in order to qualify for warranty consideration. Defective equipment or parts returned after 45 days may be subject to a restocking charge of 20% or a minimum charge of \$50.00 whichever is greater.

This warranty is in lieu of all other warranties, expressed or implied, and all other obligations or liabilities on the part of RCI Technologies, and RCI Technologies neither assumes nor authorizes any other person to assume for it any other liability in connection with any such electrical control, test or accessory equipment or accessories or parts.

EXTENDED FRS PRODUCT WARRANTY

The extended FRS Product Warranty may be purchased prior to initial delivery of the FRS unit. Any extended FRS Product Warranties requested after delivery will require an on-site inspection of the FRS unit and its installation (inspection performed at the customer's expense). The price for the extended FRS Product Warranty is 10% of the unit list price per each year and as with the standard FRS warranty, this includes parts only.





TECHNICAL ASSISTANCE

Telephone: (800) 868-2088 or (909) 305-1241

Facsimile: (909) 305-1245

E-mail: info@rcitechnologies.com

FRS 660 SYSTEM IDENTIFICATION

All FRS Systems will have a unique UL 508A listing number located inside of the left cabinet door.

