

Model: **FP 3000**
RCI Technologies
Universal Fuel Purifier

Nominal Flow..... 757.1 lts/min (200 gal/min)
 In and Out Couplings..... 3" NPT
 Top Port..... 1" NPT
 Heating Element (optional). N/A
 Sensor Port..... 1/8"
 Manual Air Purge..... Standard
 Factory Pre-Set.....
 Pressure Relief Valve.... Standard
 Drain Valve..... Standard 1" Drain Port
 Height..... 143.5 mm (56.5")
 Width..... 38.1 mm (1.50")
 Approx. Weight..... 120 lbs.

APPLICATIONS

Larger Pumping Stations

Aircraft Fueling

Fuel Docks

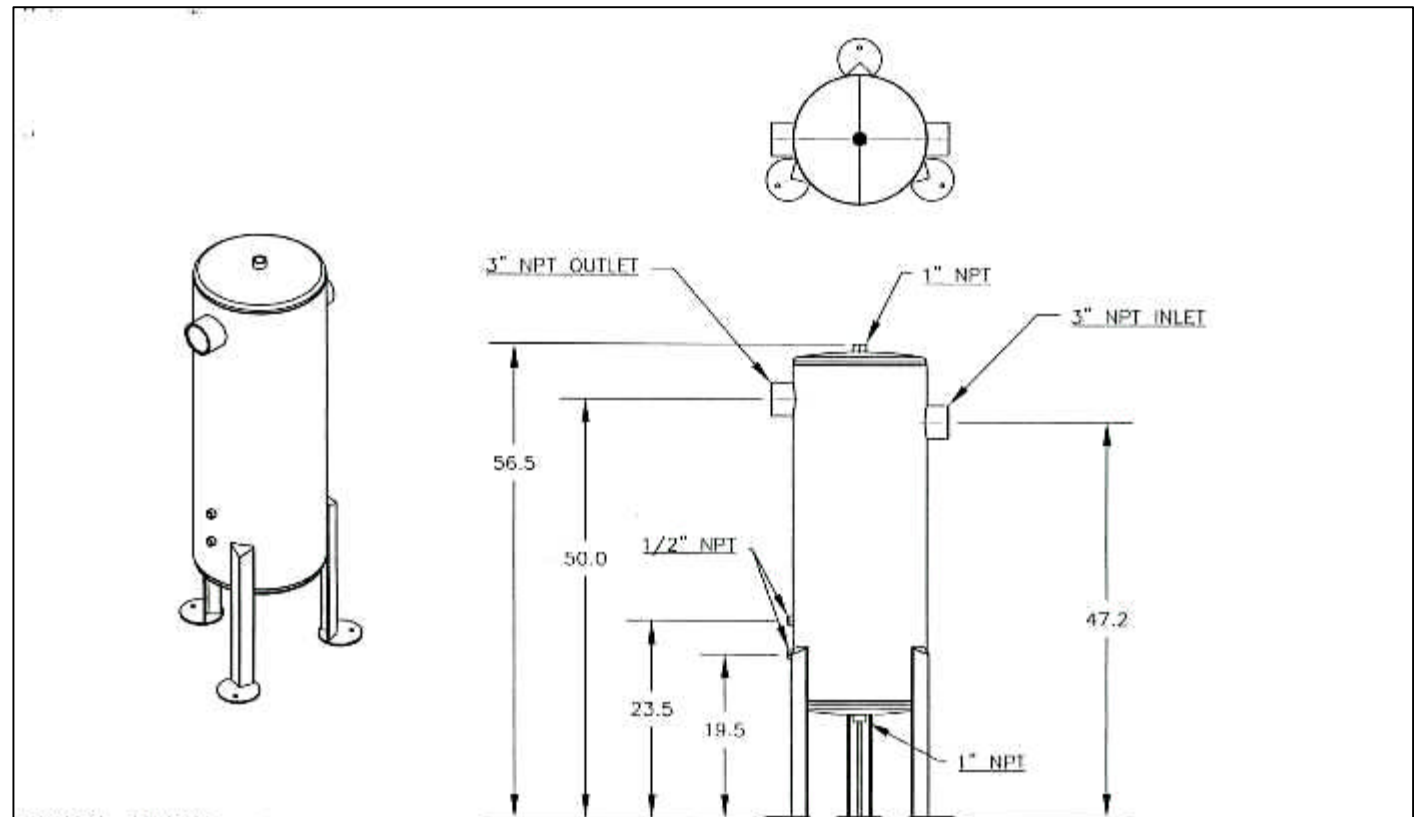

FINISH: BLACK

| | | | | | | | | | | | | | | | | | | |
|--------------|-------------|-----|------|----|------|--------------|-------------|-----|------|-------------------------------------|------|-----------------------|-------------------|----------|----|-----|------------------|-------------------|
| | | | | | | | | | | NAME FUEL/WATER SEPARATOR RCI | | DR. RLT | DATE 27 APR 05 | | | | | |
| | | | | | | | | | | | | CHK. KJM | SCALE .062"=1" | | | | | |
| | | | | | | | | | | | | MATERIAL REF: | | | | | | |
| | | | | | | | | | | RCI TECHNOLOGIES | | PART NO FP 3000-SB | | | | | | |
| TRANS NO. | CHG LET. | WAS | DATE | BY | APP. | TRANS NO. | CHG LET. | WAS | DATE | BY | APP. | XXXX | RELEASED | 04/27/05 | RT | KJM | RCI TECHNOLOGIES | SCALE .062"=1" |