

Model: **FP 1000**
RCI Technologies
Universal Fuel Purifier

Nominal Flow: 40 gal/min (151.4 lts/min)
 In & Out Couplings:.....1" NPT
 Top Port: 1/2" NPT
 Sensor Port *:..... 1/8" NPT
 Drain Port:.....1/2" Port
 Height:..... 20.5" Strap mount
 Width: 7.0"
 Gross Weight: 22 lbs.
 *Water Sensor is optional.



APPLICATIONS

Diesel Pumping Stations
 Fuel Docks
 Diesel Locomotives

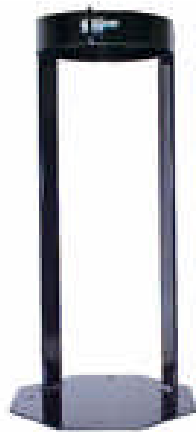

Base is optional

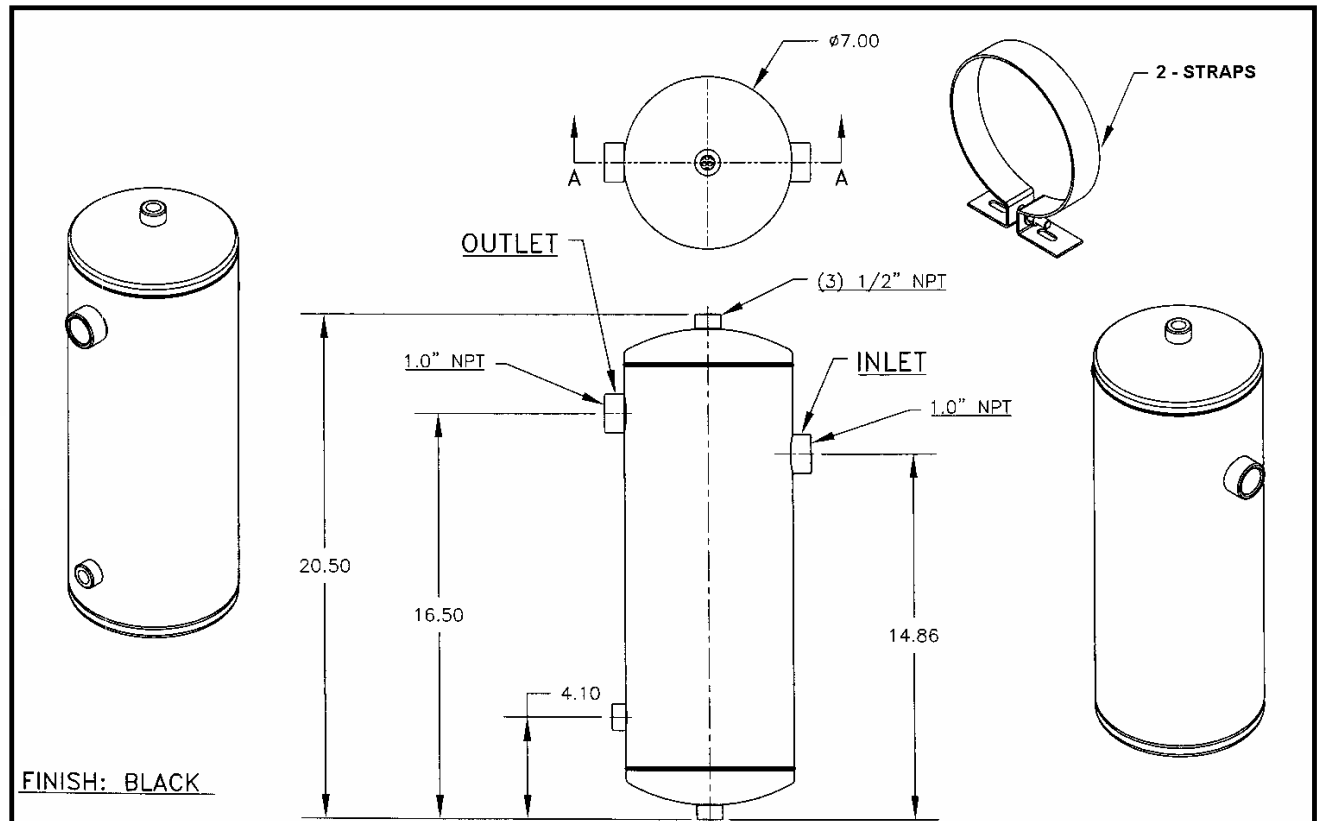

FINISH: BLACK

| | | | | | | | | | | | | | | |
|------------|-----------|-----|------|----|------|------------|-----------|-----|------|-------------------------------|------|---------------|-----------|--|
| | | | | | | | | | | NAME | | DR. | DATE | |
| | | | | | | | | | | FUEL/WATER SEPARATOR | | RLT | 01 DEC 03 | |
| | | | | | | | | | | RCI | | CK: | SCALE | |
| | | | | | | | | | | | | KJM | .187"=1" | |
| | | | | | | | | | | | | MATERIAL REF: | | |
| | | | | | | | | | | | | | | |
| | | | | | | | | | | 8822 | | RELEASED | | |
| | | | | | | | | | | 12/01/04 | | RT KJM | | |
| | | | | | | | | | | RCI TECHNOLOGIES | | SIZE | PART NO. | |
| | | | | | | | | | | SAN DIMAS, CALIFORNIA, U.S.A. | | A | FP 1000-S | |
| TRANS. NO. | CHG. LET. | WAS | DATE | BY | APP. | TRANS. NO. | CHG. LET. | WAS | DATE | BY | APP. | | | |